

► DUNE MAX











Dune Max



Dune Max MicroLook

► DUNE MAX

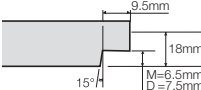
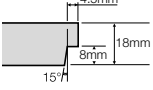

DUNE MAX	BOARD	TEGULAR	MICROLOOK
	 Prelude XL ² /TL 24 mm	 Prelude XL ² /TL 24 mm	 Prelude XL ² /TL 15 mm
	 18mm	 9.5mm 18mm 15° M=6.5mm D=7.5mm	 4.5mm 8mm 18mm 15°
	600 x 600 x 18 mm 2250 M 600 x 1200 x 18 mm 2251 M	2252 M2253 M

	α_w	NRC	125	250	500	1000	2000	4000	α_p
EN 20354 & EN 11654	0.65	0.60	0.50	0.55	0.75	0.75	0.70	0.45	

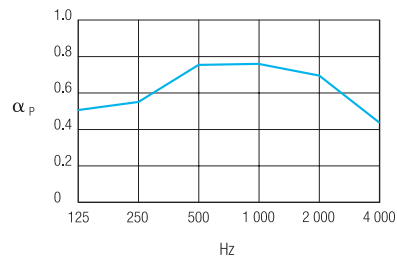

	$D_{n,w}$
EN 20140-9 & EN 717-1	35 dB

	EEA Euroclass A2-s1, d0
	CIS G1, V1, D1, T1 NPB 244-97

	$\lambda = 0.052 - 0.057 \text{ W/mK}$		$\approx 85\%$		99% RH		$\approx 4.6 \text{ kg/m}^2$
---	--	---	----------------	---	--------	---	------------------------------

Product availability may vary. Please contact ITS or visit www.armstrong-ceilings.co.uk for updated information or other sizes.
За более подробной информацией обращайтесь, пожалуйста, в представительство компании Армстронг.

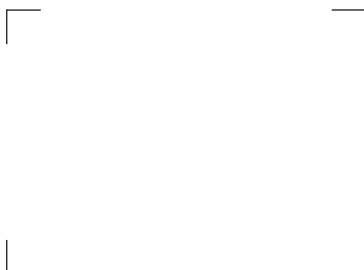

Информационный центр
Армстронг Европа ГмбХ
Московское представительство
Россия,
117198, Москва,
Ленинский пр., 113/1
Офис Е-502, Е-504
Тел.: (+7 495) 956 5100
Факс: (+7 495) 956 5101
info-cis@armstrong.com
www.armstrong.ru

Armstrong World Industry Ltd
Building Products Division
Armstrong House
38 Market Square
Uxbridge UB8 1NG
Tel: 0 800 37 18 49
Tel: 1800 409002 (ROI)
FREEPHONE
www.armstrong-ceilings.co.uk
sales-support@armstrong.com
www.armstrong-europe.com

